

Cloud Computing

Infrastructure-as-a-Service



How Businesses can Benefit from a Virtualized Datacenter

Typical small business IT needs



- File server
- Simple application server - accounts, admin, vertical specific
- Communication and collaboration
- Marketing/Sales - Ecommerce, CRM, Client portal

- Knowledge management (DM, search)
- Data mining, BI
- BC/DR, backup

Current problem (physical datacenter)

- High Capex:
 - heavy investment in infra/facility
 - equipment cost (network, server, storage, etc)
- High Opex:
 - power, cooling
 - Management
 - Manpower
- Others:
 - hardware refresh
 - limited resource
 - lack dynamic scaling
 - lack flexibility
 - high cost to achieve HA
 - prevent company from exploring IT for biz efficiency



What is VPDC (IaaS or DaaS)

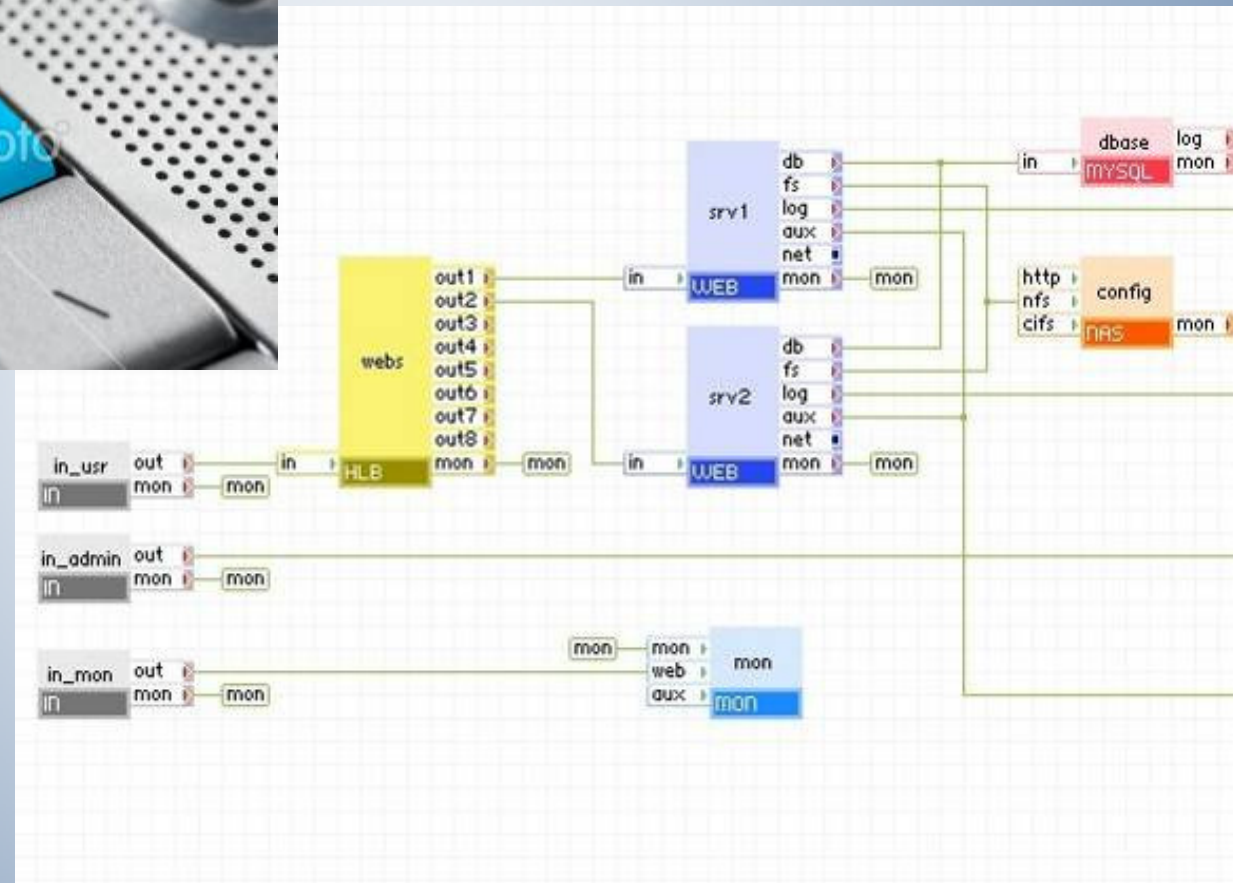

Benefits to SMEs



- Reduce Capex and Opex:
 - lower infra and management cost
 - enable agile IT department
- Gain that extra freedom:
 - flexibility, anytime, anywhere access
 - easier to embark on experimental services
- Others:
 - Global business ready, collaboration
 - BC/DR, SLA
 - Green computing
 - Mashup
 - Focus on business

Use case / Demo



- CRM web application
- BI HPC cluster